

Biogon
f/5.6–60 mm
Cat. No. 104800
 (only for reseau cameras)

H A S S E L B L A D



ZEISS

Carl Zeiss
 D-7082 Oberkochen
 West Germany

The Biogon f/5.6–60 mm is a special wide-angle lens which meets the stringent requirements of photogrammetric photography with regard to image quality and freedom from distortion. A 4 mm thick reseau plate with 25 etched reseau crosses at nominal distances of 10 mm which are maintained to within 0.005 mm, is provided for the correction of this lens.

The Biogon f/5.6–60 mm in the "Hasselblad EL Data Camera" took part in the Apollo 11 lunar landing. This wide-angle lens can also be used for normal photogrammetric purposes in the "Hasselblad MK 70" camera. Each lens is calibrated together with its camera. The corresponding data are entered in the test report which is supplied with each camera.

The Biogon f/5.6–60 mm cannot be used in normal Hasselblad cameras with reflex viewfinder.

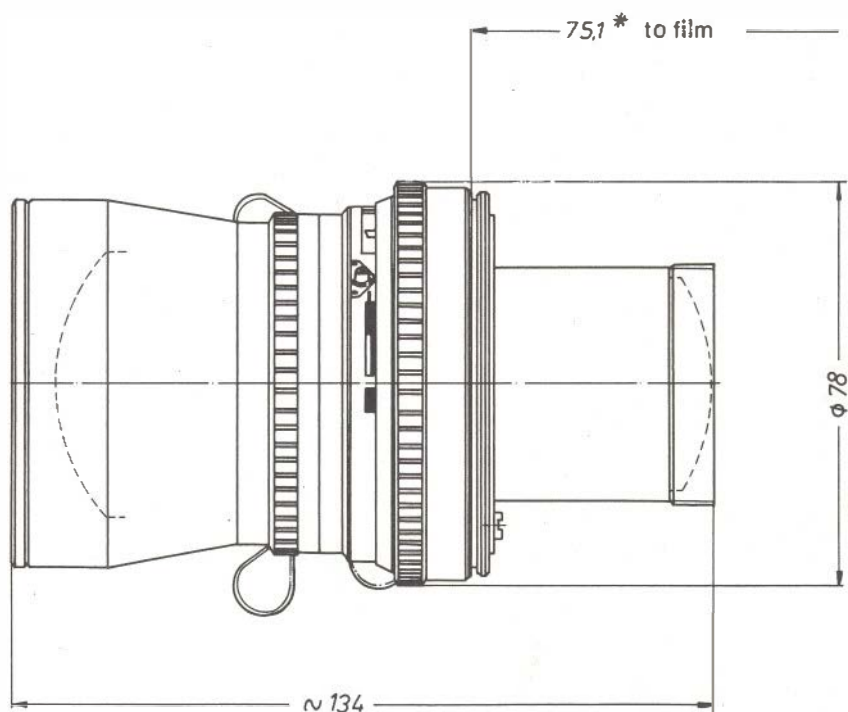

* flange focal distance with reseau

| | | | |
|--------------------------|---------------------------------------|--|--|
| Number of lens elements: | 8 | Distance range: | ∞ to 0.9 m |
| Number of components: | 5 | Position of entrance pupil: | 39.1 mm behind the first lens vertex |
| f-number: | 5.6 | Diameter of entrance pupil: | 10.9 mm |
| Focal length: | 61.1 mm | Position of exit pupil: | 61.5 mm in front of the last surface |
| Negative size: | 53 x 53 mm | Diameter of exit pupil: | 11.0 mm |
| Angular field 2w: | diagonal 63°, side 47° | Position of principal plane H: | 39.4 mm behind the first lens vertex |
| Spectral range: | visible spectrum | Position of principal plane H': | 61.1 mm in front of the last surface of the reseau plate |
| f-stop scale: | 5.6 - 8 - 11 - 16 - 22 - 32 - 45 | Distance between first and last lens vertex: | 125.5 mm (distance to the last surface of the reseau plate: 155.2 mm) |
| Mount: | Compur interchangeable shutter size 0 | | |
| Filter mounting: | adapter ring for Hasselblad series 63 | | |
| Weight: | 740 g | | |

Modulation transfer T as a function of image height u

Slit orientation tangential — — — —
sagittal —————

White light

Spatial frequencies R = 10, 20 and 40 cycles/mm

T f-number k = 5.6

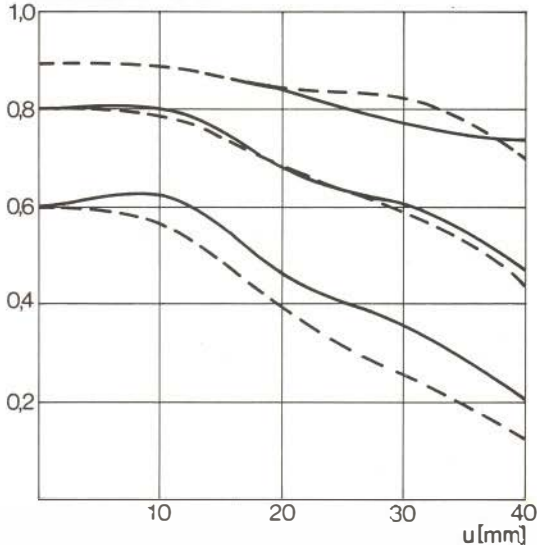

T f-number k = 8

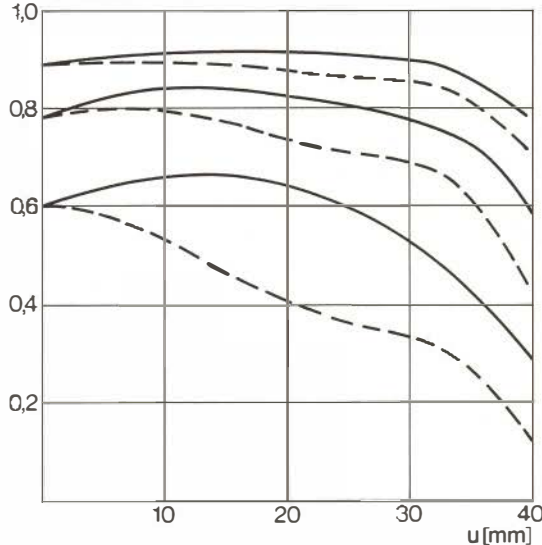

E Relative illuminance

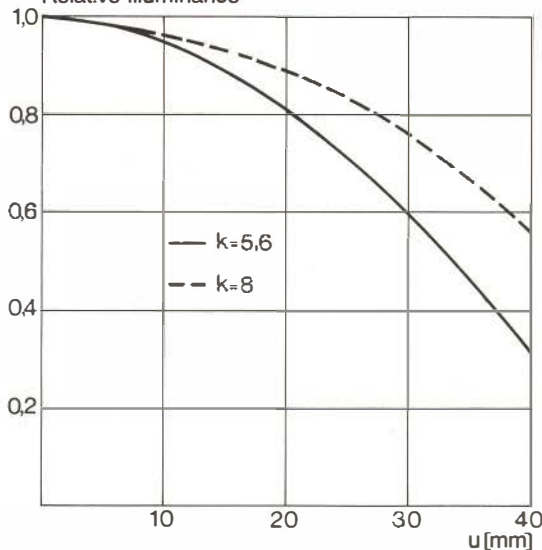

1. MTF Diagrams

The image height u – reckoned from the image center – is entered in mm on the horizontal axis of the graph. The modulation transfer T (MTF = Modulation Transfer Factor) is entered on the vertical axis. Parameters of the graph are the spatial frequencies R in cycles (line pairs) per mm given at the top right hand above the diagrams. The lowest spatial frequency corresponds to the upper pair of curves, the highest spatial frequency to the lower pair. Above each graph the f-number k is given for which the measurement was made. "White" light means that the measurement was made with a subject illumination having the approximate spectral distribution of daylight.

Unless otherwise indicated, the performance data refer to large object distances, for which normal photographic lenses are primarily used.

2. Relative illuminance

In this diagram the horizontal axis gives the image height u in mm and the vertical axis the relative illuminance E, both for full aperture and a moderately stopped-down lens. The values for E are determined taking into account vignetting and natural light decrease.

3. Distortion

Here again the image height u is entered on the horizontal axis in mm. The vertical axis gives the distortion V in % of the relevant image height. A positive value for V means that the actual image point is further from the image center than with perfectly distortion-free imaging (pincushion distortion); a negative V indicates barrel distortion.

V Distortion in mm

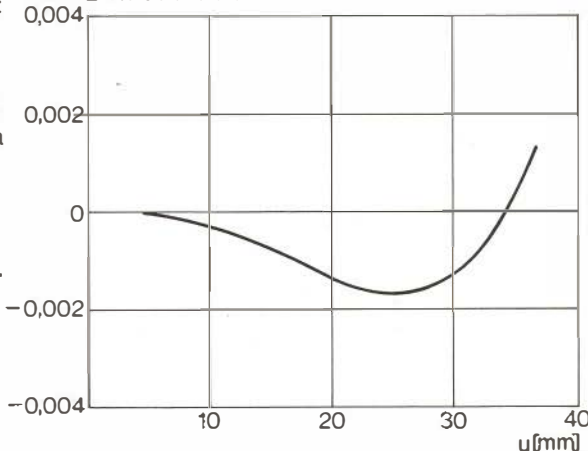

Subject to technical amendment